

OPERATION & INSTRUCTIONS

SUN|DASH Tanning System

SPA 16|24

Notice: *Any misuse, abuse, modifications, alteration, improper maintenance, improper installation, etc. of this product or its intended use will subject said party to direct responsibility and liabilities for any and all consequences resulting from such action. Furthermore, such actions will void all warranties and may relieve JK Products & Services, Inc. of any liabilities relating to said product.*

JK Products & Services, Inc.
1 Walter Kratz Drive Jonesboro, AR. 72401
1-800-643-0086

"THIS PRODUCT IS IN CONFORMITY WITH PERFORMANCE STANDARDS FOR SUNLAMP PRODUCTS UNDER 21 CFR PART 1040."

Specifications

Spa 16

Length: **84"**
 Width: **37"**
 Height: **29.5" - 54"**
 Shipping Weight: **375 Lbs.**
 No. of Lamps: **16**
 Electrical: **14 Amp @ 120Volts**
 Circuit: **120 Volt, Single phase, 20 Amp**

The SPA 16 Tanning system is designed to plug into a T-Slot receptacle. Electrical supply should include 20 AMP breaker with a 20 AMP 120V T-Slot.

Spa 24

Length: **84"**
 Width: **37"**
 Height: **29.5" - 54"**
 Shipping Weight: **450 Lbs.**
 No. of Lamps: **24**
 Electrical: **20 Amp @ 120Volts**
 Circuit: **120 Volt, Single phase, 30 Amp**

DANGER - ULTRAVIOLET RADIATION. FOLLOW INSTRUCTIONS. AVOID OVEREXPOSURE. AS WITH NATURAL SUNLIGHT, OVEREXPOSURE CAN CAUSE EYE AND SKIN INJURY AND ALLERGIC REACTIONS. REPEATED EXPOSURE MAY CAUSE PREMATURE AGING OF THE SKIN AND SKIN CANCER. WEAR PROTECTIVE EYEWEAR; FAILURE TO MAY RESULT IN SEVERE BURNS OR LONG-TERM INJURY TO EYES.

MEDICATIONS OR COSMETICS MAY INCREASE YOUR SENSITIVITY TO THE ULTRAVIOLET RADIATION. CONSULT PHYSICIAN BEFORE USING SUNLAMP IF YOU ARE USING MEDICATIONS OR HAVE A HISTORY OF SKIN PROBLEMS OR BELIEVE YOURSELF ESPECIALLY SENSITIVE TO SUNLIGHT. IF YOU DO NOT TAN IN THE SUN, YOU ARE UNLIKELY TO TAN FROM THE USE OF THIS PRODUCT.

THIS UNIT UTILIZES UVA LAMPS. REPLACE ONLY WITH **GENESIS HP 20 120W F71-T12-HO-BP-120W**.

LIE ON ACRYLIC SURFACE AND LOWER TOP SECTION. TOP SECTION WILL STOP AT 12 INCHES (305 MM) FROM BOTTOM ACRYLIC SURFACE. THE USE OF ANY OTHER POSITION MAY RESULT IN OVEREXPOSURE.

RECOMMENDED EXPOSURE SCHEDULE					
SKIN TYPE	WEEK 1 1 ST-3RD TREATMENTS	WEEK 2 4TH-6TH TREATMENTS	WEEK 3 7TH-10TH TREATMENTS	WEEK 4 11TH-15TH TREATMENTS	WEEKLY SUBSEQUENT TREATMENTS
I - SENSATIVE	Not Advised	Not Advised	Not Advised	Not Advised	Not Advised
II - FAIR	3 MIN.	7 MIN.	15 MIN.	20 MIN.	20 MIN.
III - AVERAGE	3 MIN.	7 MIN.	15 MIN.	20 MIN.	20 MIN.
IV - BROWN	3 MIN.	10 MIN.	15 MIN.	20 MIN.	20 MIN.
V - DARK BROWN	3 MIN.	10 MIN.	15 MIN.	20 MIN.	20 MIN.

MAXIMUM EXPOSURE TIME IS 20 MINUTES.

TANNING CAN BEGIN ON A REGULAR BASIS. AN APPEARANCE OF TANNING NORMALLY APPEARS AFTER A FEW EXPOSURES AND MAXIMIZES AFTER FOUR (4) WEEKS OF EXPOSURE FOLLOWING THE RECOMMENDED SCHEDULE FOR YOUR SKIN TYPE.

USE PROTECTIVE EYEWEAR, SUPER SUNNIES, WHENEVER THE EQUIPMENT IS ENERGIZED. READ THE INSTRUCTION BOOKLET BEFORE USING THIS UNIT.

INSTRUCTIONS ACCOMPANYING THIS PRODUCT SHOULD ALWAYS BE FOLLOWED TO AVOID OR MINIMIZE POTENTIAL INJURY.

Warnings and Cautions

Certain drugs - particularly those that produce photosensitivity - may cause individuals under the influence of this type drug to experience adverse effects and those people should avoid exposure to UV sources of all kinds. Doctors will advise persons taking these drugs to possible adverse effects.

It is recommended that only one person at a time should use the tanning system while in use, and advises using protective eyewear while taking a tanning session. One pair of goggles is provided with each sunbed sold.

WARNING

If you have been diagnosed by a physician as being allergic to the sun or are currently taking photosensitive medications, consult your physician before using the tanning unit.

Occasionally, persons using the tanning system will experience a slight reddening of the skin - usually in small patches - after the second or third session. This redness is often accompanied by an itching sensation. This may be nothing more than a heat "rash" caused by heat from the lamps within the system.

It is generally very limited and caused by constant contact of the skin with the acrylic surface. It should go away within approximately 24 hours and should not reappear. This rashing can be lessened or prevented by applying moisturizer lotion to the affected area after the tanning session is completed.

CAUTION

While there is no immediate clinical evidence regarding UVA exposure and its effects upon expectant mothers, it is strongly advised that expectant mothers be discouraged from using tanning unit.

MANDATORY READING

Always read and follow all instructions for proper usage prior to using any tanning system.

Remember:

1. Follow the exposure schedule in accordance with your skin type. Failure to do so may result in overexposure.
2. A tanning system is not a toy. You cannot vary the strength of the lamps in your unit.

Should you have any questions regarding the proper use of your tanning system, contact JK Products & Services at:

1-800-445-0624
8:00 a.m. to 5:00 p.m. (CST)

Care and Cleaning of Your Tanning Unit

After each session is completed, spray the acrylic surface with specially formulated UVT (ultraviolet transmitting) acrylic cleaner. Wipe the surface of the acrylic with a clean cloth. The acrylic should never

be wiped with a dry cloth because this will generate a slight static charge which will attract dust. A mild liquid detergent and water solution can be used temporarily in place of Acrylic Cleaner.

For maximum efficiency of your tanning unit, periodic cleaning of lamps, reflectors and the inside of the acrylics is required. Refer to relamping instructions for acrylic removal.

CAUTION: Do not use excessive amounts of water, any abrasive cleaners, or any spray cleaners that carry label warnings regarding reactions to contact with skin!

DO NOT USE ALCOHOL OR AMMONIA

Electrical Safety:

The tanning unit should be disconnected from the power supply before cleaning or disinfecting the inside of the acrylic. Avoid water or solution entering the lamp compartment.

RELAMPING INSTRUCTIONS

SUN|DASH SPA 16 or 24

1. Disconnect unit from power.
2. Remove acrylic from bottom unit. Locate fasteners lift plunger and turn 1/4 of a revolution. Slide acrylic back until the front edge of the acrylic is exposed. Lift the front edge and slide the acrylic forward and lift out.
3. To remove lamp rotate 90° and lift out.
4. Replace lamp by positioning pins inside lamp holder and rotate 90°. Lamp etching should always be visible to tanner after installation.
5. Clean and replace acrylic sheet. To install acrylic, slide the entire length of the rear edge of the acrylic into groove in back rail. Align the acrylic with groove in the front rail and slide forward. Turn acrylic fastener 1/4 revolution. Plunger should snap down firmly when properly installed.
6. Reconnect unit to power.
7. Refer to Care and Cleaning Instructions for information on cleaning acrylic and ordering lamps.

Timer Instructions

In Idle Mode:

Press the UP button and START/STOP keys together to display bed hours.
Press the START/STOP key to start a session.

In Run Mode:

Press the SET key to decrement session time (in minutes)
Press the START/STOP key to stop and go back to idle mode.

CAUTION:

Replacement lamps must comply with 21 CFR 1040.20.
A: Replace only with "Genesis HP 20 120W, F71-T12-HO-BP-120W".
B: When ordering lamps include make, model and serial number.

Exposure Time and Frequencies

Melanin - The brownish pigment produced by special cells in the base layer of your skin determines the individual's tan. As the skin is exposed to the ultraviolet light, the melanin is activated and combines with protein cells that rise to the skin's surface, thus producing a tan.

The amount of melanin in your body determines how quickly and dark you tan. The more melanin produced and exposure time an individual has, the faster and deeper the individual will tan.

NOTE

The tan produced by the tanning unit is a deep, rich "COSMETIC" tan. However, regardless of how dark an individual may tan on this system, it will not provide adequate protection against overexposure to natural sunlight or UVB tanning systems.

SKIN TYPE I - Not Advised

SKIN TYPE II - This is the individual that usually burns easily and severely, tans minimally or lightly and peels.

SKIN TYPE III - Often referred to as "AVERAGE" complexion, burns moderately and tans about average.

SKIN TYPE IV - This individual burns minimally, tans easily and above average with each exposure.

SKIN TYPE V - This individual's system rarely burns, tans easily and substantial

SKIN TYPE	WEEK 1 1 ST-3RD TREATMENTS	WEEK 2 4TH-6TH TREATMENTS	WEEK 3 7TH-10TH TREATMENTS	WEEK 4 11TH-15TH TREATMENTS	WEEKLY SUBSEQUENT TREATMENTS
I - SENSITIVE	Not Advised	Not Advised	Not Advised	Not Advised	Not Advised
II - FAIR	3 MIN.	7 MIN.	15 MIN.	20 MIN.	20 MIN.
III - AVERAGE	3 MIN.	7 MIN.	15 MIN.	20 MIN.	20 MIN.
IV - BROWN	3 MIN.	10 MIN.	15 MIN.	20 MIN.	20 MIN.
V - DARK BROWN	3 MIN.	10 MIN.	15 MIN.	20 MIN.	20 MIN.

Maximum Exposure Time is 20 Minutes

NOTE: Adequate ventilation of the room or booth housing the tanning unit is required for proper and comfortable operation. Your tanning unit will perform best at the ambient temperature of 75° to 90° F.

Equally important many facial makeups have oil bases and should be removed prior to a session. It is recommended that, following a tanning session, a skin moisturizer be applied. This promotes a smoother, more even looking tan.

It is recommended you do not use tanning creams, oils or lotions intended for outdoor use.

Assembly Instructions

Step 1

Remove all components from carton and place bottom unit on carpet or carton with acrylic facing the floor.

Step 2

Place leg half into position and align with holes in bottom of unit. Attach the leg half to the bottom unit with three M6 x 25 ULF screws. Repeat process on the remaining three leg halves. When all legs halves are mounted tighten securely using a phillips screw driver (not included).

(See Illustration A)

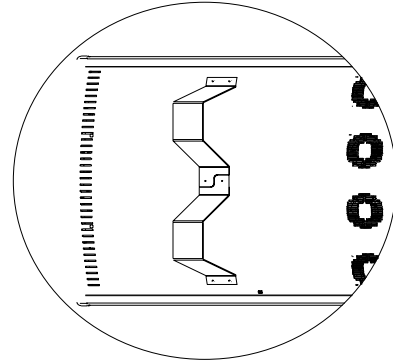

Illustration A

Step 3

Return unit to upright position. Place support brackets on the end of bottom unit and align with holes in support bracket with the threaded holes in end cap of unit. Locate the 5/16" 18 X 1" hex bolts and fasten bracket to end cap. Do not tighten securely, brackets must be slightly movable to perform Step 4. Repeat procedure for opposite support bracket. (See Illustration B)

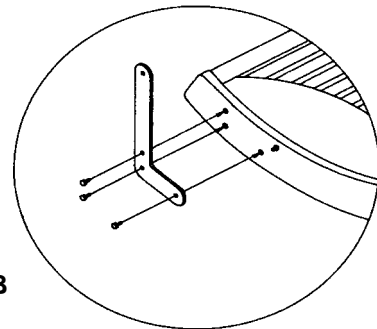

Illustration B

Step 4

Using additional adult assistance to lift top unit, place top unit into position between support brackets and align pivot studs through holes in the top of bracket. Once the canopy is aligned secure with the 3/8" acorn nuts.

Do Not Over Tighten. (See Illustration C)

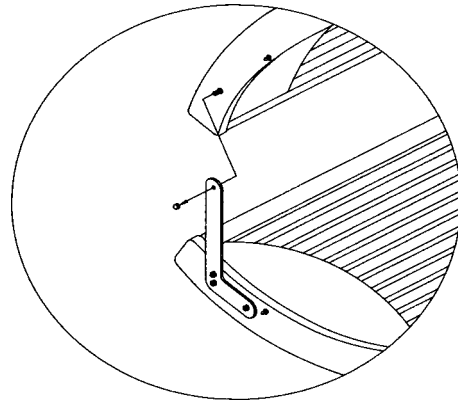

Illustration C

Step 5

Tighten 5/16" 18 X 1" hex bolts attaching bottom of support bracket securely at this time.

Step 6

Locate top unit lifting cylinders. Attach cylinder to ball stud on the bottom unit. Raise canopy and align top coupler with ball stud and attach. The larger end of the cylinder must always go up. Repeat procedure for opposite end. (See Illustration D)

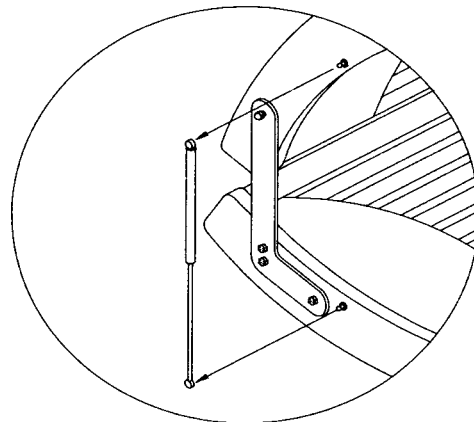

Illustration D

Step 7

Connect canopy and bottom unit power to component box assembly, align three conductor plugs from the canopy and bottom unit with receptacles in bottom of component box. To keep cords secure push cords into slots of mounting bracket.

General Troubleshooting Guide

The following troubleshooting information is divided into two sections. Section A contains items in which the owner may check without the aid of a service person. Section B contains items which must be performed by QUALIFIED SERVICE PERSONNEL ONLY. If you have any questions other than the ones listed in your troubleshooting guide, contact your dealer or distributor.

(NOTE: All tanning units are not the same, therefore some of the causes may not apply to your unit.)

General Troubleshooting (Section A)

1. Tanning unit does not operate.

CAUSE

1. No power to unit.
2. Timer is not activated.

SOLUTION

1. Check circuit breaker servicing bed.
2. Press up button, then start button.

(Note: If there is power to the unit but the display on the timer is not lighting, you may need to replace the timer. Contact JK Products & Services or your local representative for information.)

2. Lamps will not light or lamps flicker.

CAUSE

1. Lamp not seated properly in lampholder.
2. Faulty Lamp

SOLUTION

1. Remove lamp, inspect contact on lamp, and reinstall lamp securely into lampholder.
2. Replace lamp. (Refer to Instruction Manual for correct lamp.)

General Troubleshooting (Section B)

All services in the following section are to be completed by a Qualified Service Technician. This section is to aid in isolating and correcting problems which may occur and is not intended for the use by the owner. Refer to the assembly instructions included with each unit for reference in disassembling and wiring the tanning unit. Disconnect all power to the unit before servicing. Use only factory authorized components for replacement parts.

1. Tanning unit does not operate.

CAUSE

1. Incorrect connection of incoming power.
2. Faulty timer.
3. Faulty relay in bed
4. Poor wiring connections

SOLUTION

1. Check electrical connection on wiring diagram and correct as necessary.
2. Replace
3. Replace
4. Check wiring circuit against appropriate wiring diagram and correct as required.

2. Lamps will not light.

CAUSE

1. Poor wiring crimp at lampholder,
2. Faulty or damaged lampholder.
3. Incoming power to unit incorrect
4. Faulty ballast
5. Loose power wire to ballast

SOLUTION

1. Check for loose wire and repair.
2. Replace.
3. Check incoming voltage and correct to requirements.
4. Locate and replace
5. Locate loose wire and repair.

Parts Diagram

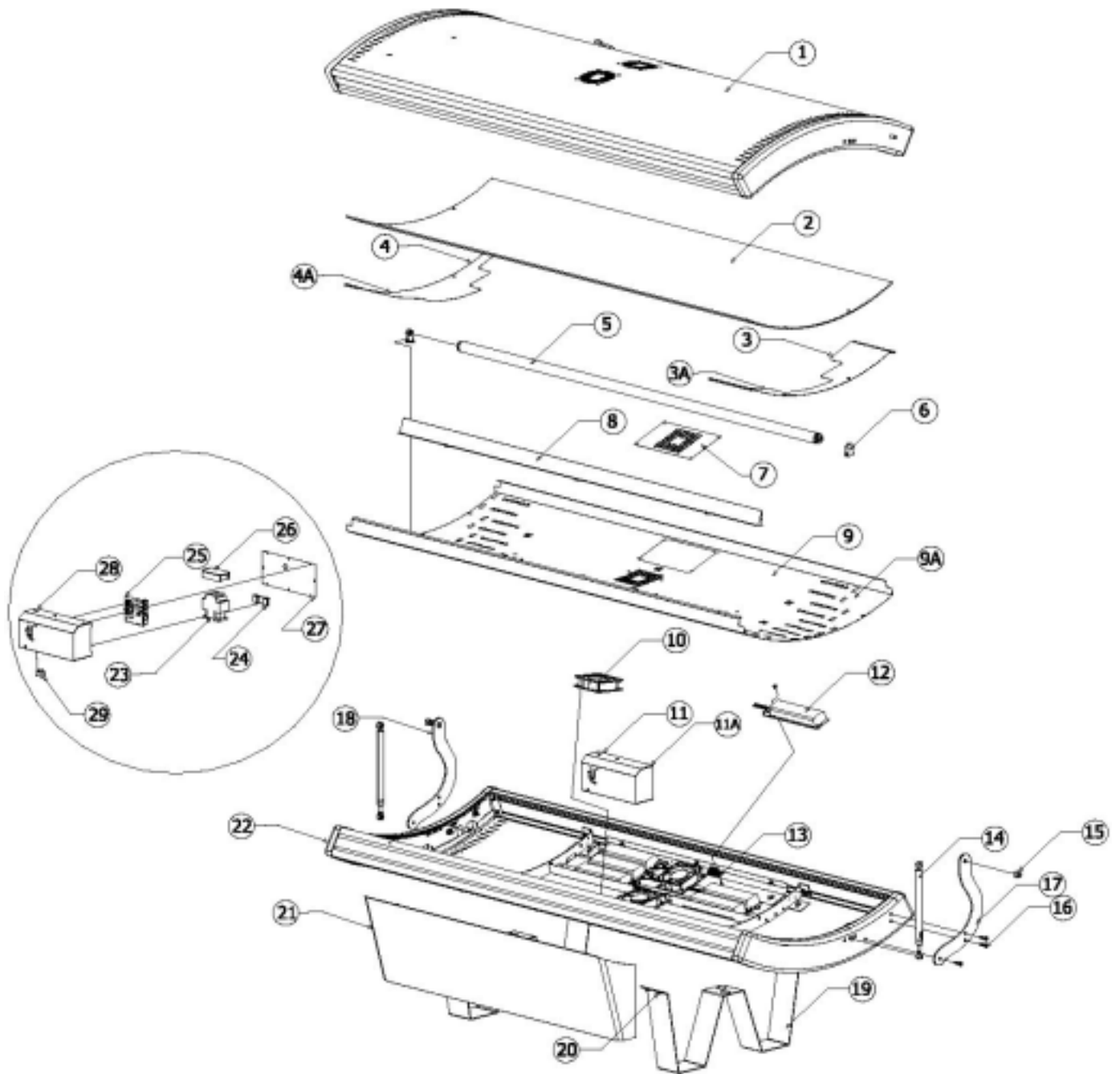

Parts List

Part Number	Description
1. 0700725502	CANOPY SHELL ASSY EL08
2. 0040711401	ACRYLIC TOP AND BOTTOM EL08
3. 0090725502	LAMP COVER BF/TH WHITE SPA24
3A .0010735201	LAMP COVER BF/TH WHITE SPA16
4. 0090725501	LAMP COVER BH/TF WHITE SPA24
4A .0010735202	LAMP COVER BH/TF WHITE SPA16
6. 0000012321	LAMPHOLDER,BIPIN W/O STARTER
7. 0010724701	BALLAST ACCESS PANEL
8. 0010713403	ACRYLIC BRACE EL08
10. 0032002410	FAN, 110 CFM 120V
12. 0055005051	BALLAST, ASSY SMARTCELL
13. 0037002682	TERM BLOCK, 16 POS
14. 0090724801	GAS SPRING 70LBS EL08
15. 0022003245	ACORN NUT 3/8-16
16. 0020003029	HEX HEAD BOLT 5/16-18 X 1
17. 7000730203	PIVOT ARM FOOT SIDE
18. 7000730201	PIVOT ARM HEAD SIDE
19. 0010800317	LEG HALF EL08
20. 0000051649	M6X25 ULF PLATED SCREW
21. 0010735301	FRONT COVER SPA24 WHITE
23. 0035002293	RELAY,120V AC 25 AMP
24. 0000012382	COIL SUPPRESSOR MODULE
25. 0038003001	TIMER,ELO5 TMAX 3A 20 MIN
26. 0030730501	TIMER MODULE "BRICK" 20 MIN
29. 0030715701	RECEPTACLE 110VAC 15A IEC320

JK Products & Services

Limited Warranty

JK Products & Services warrants its products to be free from defects in materials and workmanship under intended normal use as described in the unit's Operation and Instruction Manual, for a period of one (1) year from date of sale.

This Limited Warranty applies only to the original purchaser of the equipment through JK Products & Services or its authorized dealer or distributor, and is not transferable.

JK Products & Service's obligations under this warranty are limited to repair or replacement of any defective part without charge for that part to the original purchaser, with the following exceptions:

- A. Fluorescent lamps are warranted against defects for a period of thirty (30) days from date of sale.
- B. Only parts obtained through JK Products & Services, its authorized dealers or distributors may be used. Transportation costs for parts shipped to the consumer and the return of defective parts to JK Products & Services are not included.
- C. Labor will be furnished without charge for ninety (90) days from date of purchase only. All labor and related charges must be authorized by JK Products & Services prior to start of repairs, and must coincide with JK Products & Services established rates and time allotment policy.
- D. Acrylic: Refer to Manufacturer's Acrylic Warranty Policy.

It is imperative that the original customer completes and returns the enclosed warranty card within 10 days after purchase to insure valid registration and coverage for potential claims.

If the warranty card is not registered, proof of purchase from JK Products & Services or its authorized dealer or distributor will be required prior to any consideration on warranty claims. This could result in service delays.

This warranty is extended to the individual or legal entity, whose name appears on the warranty registration card filed with JK Products & Services, or whose name appears on the original sale document and may not be transferred to any other individual or legal entity.

This warranty does not apply to any failure of the product, or any parts of the product due to alterations, modifications, misuse, abuse, accident, improper maintenance, improper installation, acts of God or if the serial number on the product has been removed, altered or defaced. Adequate packaging must be used for returned goods to prevent freight damage.

THERE ARE NO WARRANTIES WHICH EXTEND BEYOND THE DESCRIPTION ON THE FACE HEREOF. THERE IS NO EXPRESS OR IMPLIED WARRANTY OF FITNESS OR MERCHANTABILITY.

THE REMEDIES PROVIDED IN THIS LIMITED WARRANTY ARE THE EXCLUSIVE REMEDIES PROVIDED TO THE PURCHASER BY JK PRODUCTS & SERVICES AND ARE PROVIDED IN SUBSTITUTION OF ALL OTHER REMEDIES. CONSEQUENTIAL AND INCIDENTAL DAMAGES ARE EXCLUDED.

No person, firm or corporation is authorized to obligate JK Products & Services for any liability in connection with the sale or use of these goods.

Limited Acrylic Warranty

JK Products & Services warrants its acrylic sheets to be free from defects in material and workmanship, under intended normal use, for a period of one (1) year from date of sale of the tanning bed. Due to the tanning lotions, cosmetics, disinfectant and improper cleaners used on tanning surfaces that cannot be controlled by JK Products & Services, after the first thirty (30) days of warranty period. Acrylic will be subject to a prorated cost to the consumer on breakage.

JK Product & Service's obligations do not include transportation charges on replacement acrylic.

JK Products & Services assumes no liability for the cost of removing defective sheets or installing replacement sheets, nor for damage to persons or property.

To make a claim, contact an authorized dealer or distributor of JK Products & Services or JK Products Service Department with the model number, the serial number, and the date of purchase of the bed in which the acrylic will be used.

THERE ARE NO WARRANTIES WHICH EXTEND BEYOND THE DESCRIPTION ON THE FACE HEREOF. THERE IS NO EXPRESS OR IMPLIED WARRANTY OF FITNESS OR MERCHANTABILITY.

THE REMEDIES PROVIDED IN THIS LIMITED WARRANTY ARE THE EXCLUSIVE REMEDIES PROVIDED TO THE PURCHASER BY JK PRODUCTS & SERVICES AND ARE PROVIDED IN SUBSTITUTION OF ALL OTHER REMEDIES - CONSEQUENTIAL AND INCIDENTAL DAMAGES ARE EXCLUDED.

JK Products & Services
1 Walter Kratz Drive
Jonesboro, Arkansas 72402
1-800-445-0624

Warranty Claims

Policy & Procedures

1. When to file a Warranty Claim:

In the event that your tanning system is not functioning properly under intended normal use as described in the unit's Operation and Instruction Manual, you may then have established cause to file a Warranty Claim.

NOTE: Both the tanning system and legal registered owner must meet the criteria established under JK Products & Service's Limited Warranty as described in this manual before any Warranty Claim will be considered.

2. Where to call to place a Warranty Claim:

JK Products & Services is supported nationwide by an extensive dealer/distributor network through whom the majority of our units are sold. These dealers/distributors are required by contract to stock sufficient parts to meet the various warranty and nonwarranty needs of their customers.

Therefore, in order for you to properly file a Warranty Claim, you must locate the name and phone number of the dealer/distributor through whom you purchased your unit. Normally this information can be easily located either on your paid invoice or other proof of purchase documentation that you received when taking delivery of the unit.

Next, notify the dealer/distributor of the serial number, model number and date unit was purchased. This will initiate the Warranty Claim process.

Upon determination of the problem, your dealer/distributor can then supply you with the part(s) and proper instructions to return your unit to working order.

Each dealer/distributor has their own internal procedure for handling Warranty Claims and credits.

NOTE: JK Products & Services, the manufacturer, does not involve itself in the direct handling of a Warranty Claim except where mitigating circumstances apply and where required by law.
